

THE XENA 2K VIDEO CARD IS AJA'S TOP-OF-THE-LINE CARD FOR WINDOWS XP, DELIVERING UNCOMPRESSED SD, HD AND DUAL LINK HD AND ENABLING CUSTOMERS TO WORK WITH 2K FRAMES IN A FLEXIBLE AND FUTURE-SAFE ARCHITECTURE.

XENA 2K's 4-lane PCI-Express bus interface plus our own integrated AJA drivers team up perfectly with Windows XP and Adobe Premier Pro to give you unparalleled power and efficiency. Supporting any uncompressed SD or HD format, including 2K and Dual Link, XENA 2K captures and plays back uncompressed 10-bit and 8-bit digital video and 24-bit 48kHz digital audio in standard definition (SMPTE 259M), high definition (SMPTE 292M), and Dual Link high definition (SMPTE 372M).



AJA Machina™ Application



XENA 2Ke Shown

AJA XENA PLUG-INS

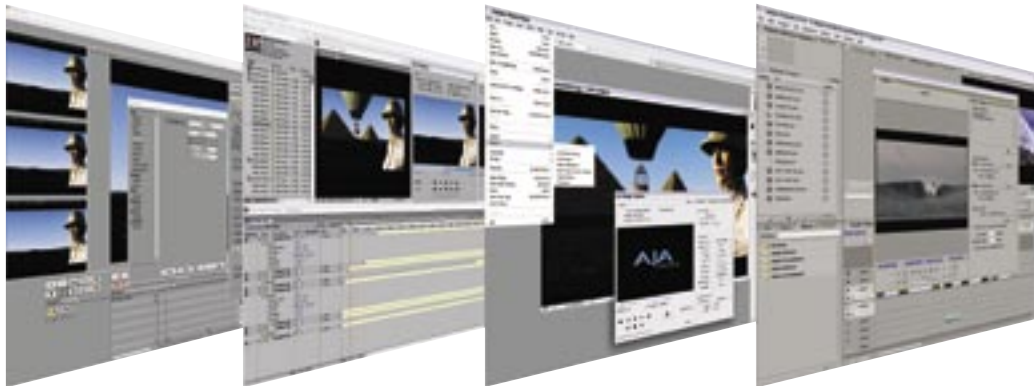

Autodesk Combustion

After Effects

Adobe Photoshop

Adobe Premiere Pro

FEATURES

- SDI, HD-SDI, Dual Link SD and HD-SDI 4:4:4, and 4:4:4:4, HSDL
- AJA XENA software plug-ins and support for Adobe Premiere Pro 2.0, Adobe After Effects 7.0, Photoshop CS/CS2, Autodesk Combustion 4 and Eyeon Fusion5 plugins and support
- AJA Machina software
- Native support for uncompressed DPX, Cineon, TGA, TIFF, BMP, YUV, and AVI and QuickTime files
- 2K frame format support
- HSDL support
- Look Up Table support (LUT)
- 4-lane PCI-express bus interface (XENA 2Ke)
- PCI-X 133 interface (XENA 2K)
- Broadcast-quality hardware 10-bit up-convert, down-convert and cross-convert
- 12-bit HD component and SD component/composite analog output
- 8-channel 48k and 96k AES, and 16-channel embedded audio
- RS-422 machine control
- Cables standard, K3-Box breakout optional
- 3-year international warranty

DUAL LINK

XENA 2K supports Dual Link 4:4:4 HD-SDI, a new technology. Commonly known as Sony HDCAM SR or Thompson Viper Format, XENA 2K Dual Link supports full bandwidth 4:4:4 RGB at 10-bits (12-bit capable) for 1080i, 1080p, and 720p formats. XENA 2K can also convert between 4:4:4 and 4:2:2 formats for Single Link HD-SDI output.

2K WORKFLOW

The XENA 2K path offers significant cost and labor savings over a tape-based approach to 2K. In a unique development for customers on Windows XP, you can go straight from telecine to disk with 2K media, eliminating both the need for tape stock and the process of digitizing tapes for the nonlinear editor. The additional 2K support in XENA 2K will benefit large, full-service facilities as well as boutique facilities entering the 2K "film as digital" landscape.

2K telecine to XENA 2K saves time and steps in the process by directly creating 2K DPX, QuickTime™ Cineon, AVI, TGA, TIFF or BMP files. Material can be played out at 2K via High Speed Data Link (HSDL) at 15 fps, offering further synergy with other 2K products available and already in use in the market.

Additionally, XENA 2K allows 2K files to be viewed on HD 1080 24P-supported video monitors, lowering the price barrier for recording to tape and viewing 2K material. This 1080 HD payout can also be down-converted to SD in realtime, giving the 2K DI pipeline a powerful solution for multi-format video payout of 2K material.

By generating 2K files during the digitize phase, different parts of the process—delivery of full-resolution media for shots intended for visual effects, for example—can be done much earlier. Offline editing can be done in Adobe Premiere Pro and because of the flexibility of Adobe Premiere Pro and Windows, even a 2K online is possible.

XENA 2K is the ultimate uncompressed capture card for seamless operation with and Adobe Premiere Pro on Windows PC. Supporting any uncompressed SD or HD format, including Dual Link and 2K, XENA 2K captures and plays back uncompressed 10-bit and 8-bit digital video and 24-bit digital audio, providing unparalleled power and workflow efficiency. XENA 2K also includes a variety of 10-bit broadcast-quality features, such as hardware-based up-, down- and cross-conversion to and from HD.

XENA 2K is available in two flavors: for PCI/PCI-X compatibility as the XENA 2K, and for 4-lane PCIe compatibility as the XENA 2Ke. Both cards are identical in features and in video and audio connections, and use the same optional K3-Box breakout box. Choose the card that best suits your workstation!

BROADCAST-QUALITY CONVERSION

XENA 2K features full 10-bit, broadcast-quality, motion-adaptive SD to HD up-conversion, HD to SD down-conversion, HD cross-conversion and automatic HD/SD 12-bit component analog output. That's equivalent to rolling AJA's stand-alone HD D/A converter, HD to SD down-converter, and our SD to HD up-converter into one convenient, cost-efficient XENA 2K board—at half the price. The quality is identical to AJA's award-winning stand-alone products, and all functionality is hardware-based, making it available full time, all the time, on digitize or playback. XENA 2K will address your needs with support for hardware-based 1080-to-720 or 720-to-1080 cross-conversion. This powerful feature further streamlines dailies and deliverables creation at true broadcast picture quality in realtime.

AUDIO

XENA 2K's extensive audio support makes installation a breeze, working with 8-channel 24-bit AES audio via XLR (balanced) connections, and 16-channel embedded 24-bit embedded SDI/HD-SDI audio.

XENA 2K also features high-quality input sample-rate conversion on AES inputs, which eliminates the need for audio source synchronization.

FLEXIBLE I/O

XENA 2K boasts two HD/SD SDI video inputs and outputs and one component analog output, each independently switchable between HD and SD (SD analog can be configured as composite). For example, if you are working in HD, you can have simultaneous HDSDI, SDI and HD or SD component analog output. Using XENA 2K's full-time format conversion features, monitoring can be as simple as a single composite monitor for both SD and HD projects. Dual Link can be monitored via Dual Link HD-SDI outputs, Single Link HD-SDI, or HD component analog.

When you plug in XENA 2K's breakout cables, they automatically configure. For SDI video, the card features two HD/SD inputs and two outputs for Single or Dual Link, one connection for Genlock input, and three for HD/SD component analog video out. Also included is a 9-pin D connector for RS-422 machine control. The SDI inputs and outputs use a separate cable with special mini-BNC connectors on one end and full-sized BNCs on the other for ease of connection and superior reliability.

The K3-Box for XENA 2K simplifies interfacing by offering a 19-inch, 1RU rack-mountable breakout box that attaches to the XENA 2K with just two cables. This option offers all the same inputs and outputs as the standard breakout cable, and can be easily rackmounted or placed on top of a broadcast monitor or editing desk. Additional functionality includes simultaneous XLR and BNC AES output, 2-channel RCA analog audio monitoring, and looping BNC Genlock reference connectors.

If you're using a digital Betacam deck, HDCAM, DVCPRO HD, D5, D9, or even an HDCAM SR, you'll have the proper connections.

XENA 2K

All of this adds up to the most reliable, feature rich, and highest performance card available for Windows XP and Adobe Premiere Pro. XENA 2K represents the next generation of technology from AJA.

INCREDIBLE 3-YEAR WARRANTY

AJA Video warrants that XENA products will be free from defects in materials and workmanship for a period of three years from the date of purchase.

ABOUT AJA VIDEO SYSTEMS, INC.

Since 1993, AJA Video has been a leading manufacturer of high-quality and cost-effective digital video interface, conversion and Desktop solutions supporting the professional broadcast and post-production markets.

With headquarters in Grass Valley, California, AJA maintains an extensive sales channel of dealers and systems integrators around the world. For further information, please see our website www.aja.com.

XENA 2K Breakout Cables (Supplied)



K3-Box for XENA 2K (Optional)

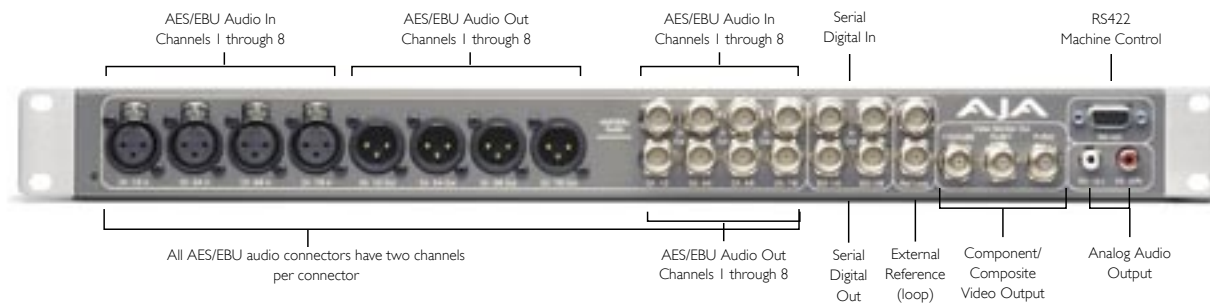

XENA 2K Standard XLR Breakout Cable

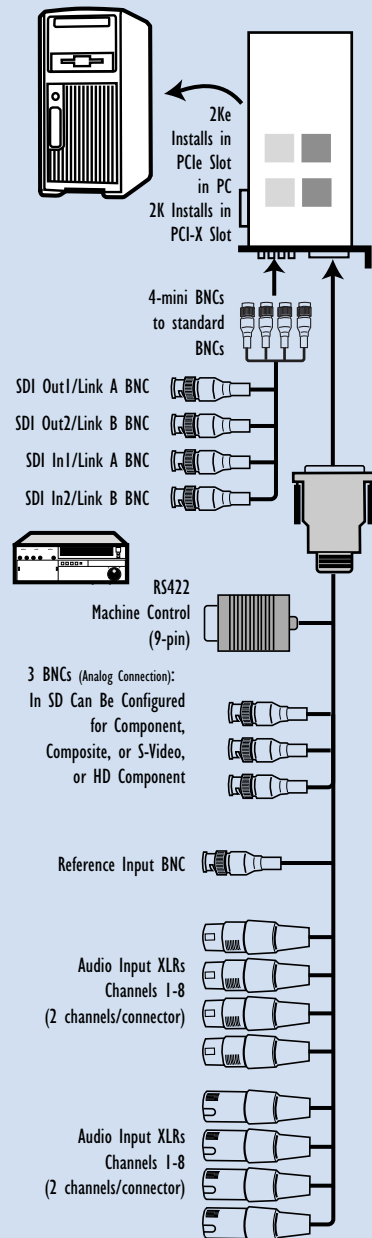

XENA 2Ke and 2K Specifications

XENA 2K
PCI and PCI-X compatible

XENA 2Ke
PCIe 4-lane compatible

Video Formats

SD:
525i 29.97
625i 25
HD:
720p Variable Frame Rate
(23.976, 24, 29.97, and 30)

720p 50
720p 59.94
720p 60
1080i 25
1080i 29.97
1080i 30
1080psf 23.98
1080p 24
1080psf 24
1080p 25
1080psf 25
1080p 29.97
1080psf 29.97
1080p 30
1080psf 30
1080p 50
1080p 59.94
1080p 60

2K:
2048 x 1080p 23.976
2048 x 1080psf 23.976
2048 x 1080p 24
2048 x 1080psf 24
2048 x 1556psf 14.98
2048 x 1556psf 15
2048 x 1556psf 23.98

Video Input

HD-SDI/SDI, SMPTE-259/292/296
Dual-link HD 4:4:4
2K HSDL (except 2048 x 1556 psf 23.98)

Video Output

Digital:
HD-SDI/SDI, SMPTE-259/292/296
Dual-link HD 4:4:4 2K HSDL

Analog:
SD and HD Output, 12-bits, BNC
HD: YPbPr, RGB
SD: YPbPr, RGB (component mode)
Composite/YC (composite mode)
12-bit D/A

Audio

16/24/32-bit 48KHz synchronous
8-channel SDI/HD-SDI embedded audio
sample rate conversion on AES inputs
(no source synchronization required)

Up-Conversion

Hardware 10-bit
Aspect Conversion modes:
Anamorphic: (full-screen)

XENA|2K

Pillar box 4:3: results in a 4:3 image
in center of screen with black sidebars
Zoom 14:9: results in a 4:3 image zoomed
slightly to fill a 14:9 image with
black sidebars
Zoom Letterbox: zooms a 16:9 Letterbox
source to full screen
Zoom Wide: results in a combination of
zoom and horizontal stretch to fill a 16:9
screen; this setting can introduce a small
aspect ratio change

Down-Conversion

Hardware 10-bit
Anamorphic: full-screen
Letterbox: 16:9 image with black top and
bottom
Crop: image is cropped for full screen
image

Cross-Conversion

Hardware 10-bit
1080i to 720p
720p to 1080i

Reference Input

Analog Color or HD Tri-level
1 BNC on standard breakout cable
(75 ohm terminating)

Machine Control

RS-422, Sony 9-pin protocol.

AJA Video Systems Inc.
P.O. Box 1033 • Grass Valley, California 95945
800.251.4224 • 530.274.2048 • www.aja.com

AS PASSIONATE AS YOU ARE
AJA
VIDEO SYSTEMS