

Trademarks

AJA, Io, and Kona are trademarks of AJA Video, Inc. All other trademarks are the property of their respective holders.

Notice

Copyright © 2007 AJA Video, Inc. All rights reserved. All information in this manual is subject to change without notice. No part of the document may be reproduced or transmitted in any form, or by any means, electronic or mechanical, including photocopying or recording, without the express written permission of AJA Inc.

FCC Emission Information

This equipment has been tested and found to comply with the limits for a Class A digital device, pursuant to Part 15 of the FCC Rules. These limits are designed to provide reasonable protection against harmful interference when the equipment is operated in a commercial environment. This equipment generates, uses and can radiate radio frequency energy and, if not installed and used in accordance with the instruction manual, may cause harmful interference to radio communications. Operation of this equipment in a residential area is likely to cause harmful interference in which case the user will be required to correct the interference at his own expense. Changes or modifications not expressly approved by AJA Video can effect emission compliance and could void the user's authority to operate this equipment.

Contacting Support

To contact AJA Video for sales or support, use any of the following methods:

443 Crown Point Circle, Grass Valley, CA. 95945 USA

Telephone: +1.800.251.4224 or +1.530.274.2048

Fax: +1.530.274.9442

Web: <http://www.aja.com>

Support Email: support@aja.com

Sales Email: sales@aja.com

When calling for support, have all information on the product (serial number etc.) at hand prior to calling.

Limited Warranty

AJA Video warrants that this product will be free from defects in materials and workmanship for a period of five years from the date of purchase. If a product proves to be defective during this warranty period, AJA Video, at its option, will either repair the defective product without charge for parts and labor, or will provide a replacement in exchange for the defective product.

In order to obtain service under this warranty, you the Customer, must notify AJA Video of the defect before the expiration of the warranty period and make suitable arrangements for the performance of service. The Customer shall be responsible for packaging and shipping the defective product to a designated service center nominated by AJA Video, with shipping charges prepaid. AJA Video shall pay for the return of the product to the Customer if the shipment is to a location within the country in which the AJA Video service center is located. Customer shall be responsible for paying all shipping charges, insurance, duties, taxes, and any other charges for products returned to any other locations.

This warranty shall not apply to any defect, failure or damage caused by improper use or improper or inadequate maintenance and care. AJA Video shall not be obligated to furnish service under this warranty a) to repair damage resulting from attempts by personnel other than AJA Video representatives to install, repair or service the product, b) to repair damage resulting from improper use or connection to incompatible equipment, c) to repair any damage or malfunction caused by the use of non-AJA Video parts or supplies, or d) to service a product that has been modified or integrated with other products when the effect of such a modification or integration increases the time or difficulty of servicing the product.

THIS WARRANTY IS GIVEN BY AJA VIDEO IN LIEU OF ANY OTHER WARRANTIES, EXPRESS OR IMPLIED. AJA VIDEO AND ITS VENDORS DISCLAIM ANY IMPLIED WARRANTIES OF MERCHANTABILITY OR FITNESS FOR A PARTICULAR PURPOSE. AJA VIDEO'S RESPONSIBILITY TO REPAIR OR REPLACE DEFECTIVE PRODUCTS IS THE WHOLE AND EXCLUSIVE REMEDY PROVIDED TO THE CUSTOMER FOR ANY INDIRECT, SPECIAL, INCIDENTAL OR CONSEQUENTIAL DAMAGES IRRESPECTIVE OF WHETHER AJA VIDEO OR THE VENDOR HAS ADVANCE NOTICE OF THE POSSIBILITY OF SUCH DAMAGES.

Introduction

The AJA Video R20CE SDI to Analog Video Encoder produces high quality NTSC or PAL 10-bit encoded video from SMPTE 259M SDI inputs. Three additional analog outputs can be configured as duplicates of the composite output, or used for component output. When configured for component video, the R20CE can output Y/C (S-Video), YPbPr (SMPTE, EBU-N10), Betacam, or RGB.

The R20CE also serves as an SDI distribution amplifier, providing 2 re-clocked outputs of the SDI input source. The R20CE is compatible with the AJA FRI IRU 4 slot frame or the FR2 2RU 10 slot frame.

The component and composite outputs incorporate optimum chroma filtering and independent pedestal configuration. The R20CE also features an exclusive PLL jitter filter/memory to reduce the effects of SDI jitter on the output analog video. This feature, along with the precision 4x oversampled D/A filters, provides high quality analog outputs, with very low phase noise in the composite outputs.

The optional AJA model FSG (Frame Sync/Genlock) Module allows genlock to an external reference with full timing adjustment. Without the FSG Module, the reference input provides color frame timing.

Features

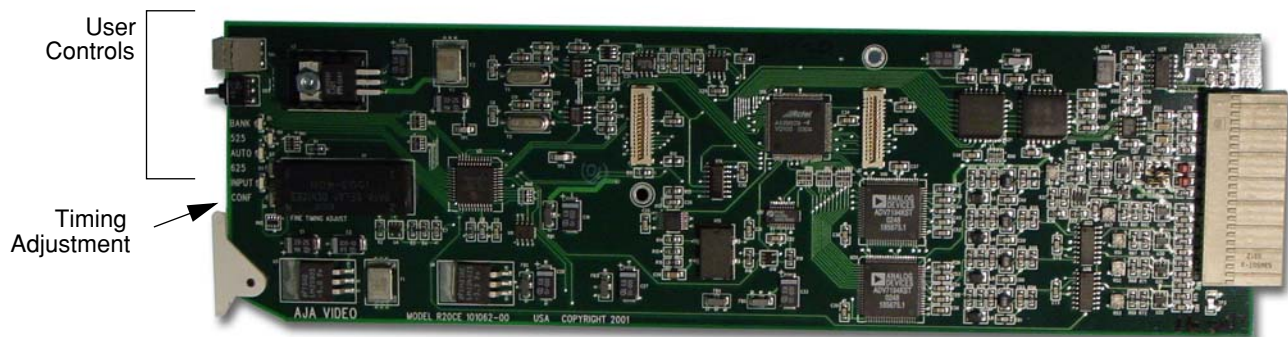

R20CE Card Module, Side View

- High quality 10-bit encoding, 4 times oversampling
- SDI Input, SMPTE 259M
- Two SDI outputs (SMPTE 259M) (equalized and re-clocked copies of the SDI input)
- Four analog outputs (configurable as 4 composite, or 1 composite and R/G/B, Y/Pb/Pr, or Y/C)i.
- Y/Pb/Pr selectable for SMPTE/EBU levels or Betacam levels (Y, R-Y, B-Y)
- Automatic NTSC/PAL selection
- Configurable pedestal and narrow/wide H/V blanking
- Frame Sync/Genlock option with reference input and full timing adjustment~
- Locks composite output Color Framing sequence to external reference without Frame Sync/Genlock option,.
- Plug compatible with several other manufacturers' video frames
- Compatible with Leitch 6800 Series Frames

Block Diagram

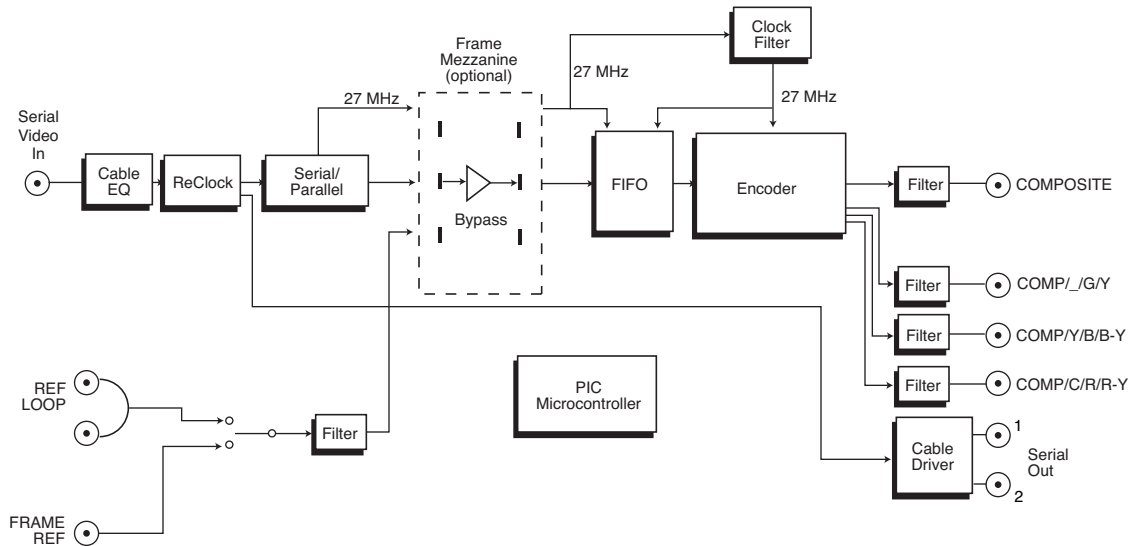

R20CE 10-bit Encoder, Block Diagram

I/O Connections

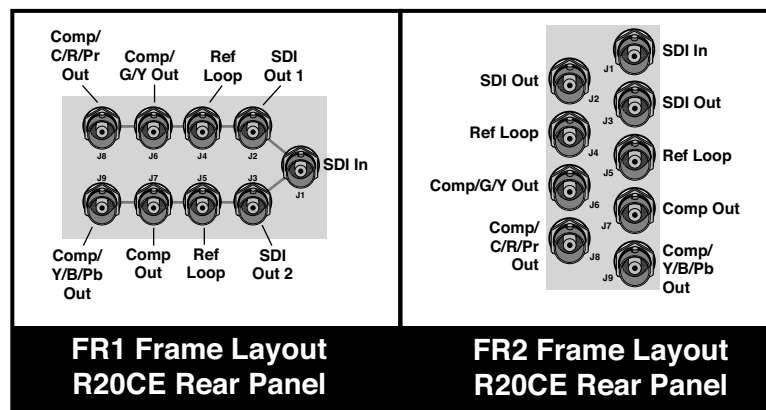

FR1 and FR2 BNC Connector Assignments, R20CE Card Module

When the R20CE module is installed in an AJA FR1 or FR2 frame, a corresponding group of 9 BNCs on the rear panel then provide I/O for the module. The illustration above shows the connector assignments for both the FR1 and FR2 when used with the R20CE.

Note: See the topic “*External Reference Information*” later in this manual for information on use of the *Ref Loop* BNCs versus the FR1/FR2 frame reference BNC when connecting an external reference video signal.

User Controls

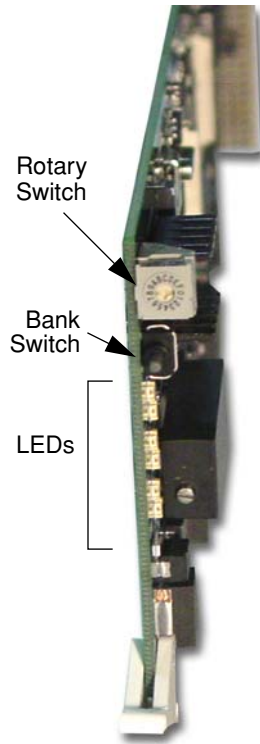

The user interface for the R20CE includes a 16 position hex rotary switch, a momentary action up/down toggle switch, and 6 LEDs. Use the rotary switch to select a function and then adjust the function using the toggle switch. The BANK Led allows two banks of functions to be accessed, The LEDs are numbered 1-6 from top to bottom. The LEDs are labeled as follows:

LED	FUNCTION
1	BANK (OFF=Bank 0 ON=Bank 1)
2	525
3	AUTO (auto 525/625 select)
4	625
5	VID (video detected at input)
6	CONFIRM (for signaling memory load, errors, etc.)

Control Functions

The following tables describe the functions controlled by the rotary switch and toggle switch user interface. To access a particular function, set the hex rotary switch to the appropriate function, and then adjust the function by flipping the toggle switch. For ON/OFF-type functions, such as Setup/NoSetup selection, moving the toggle switch to the UP/LEFT position sets the function and moving the switch DOWN/RIGHT clears the function. Using the toggle with multi-value functions, such as INPUT MODE, rotates through all the possible choices for the function. To control variables, such as framesync delay, the value of the function will be incremented or decremented each time the switch is momentarily moved either up, or down respectively. Holding the switch in either position will cause the function to automatically begin incrementing or decrementing—after a two second pause. On functions having more than two selections, using the toggle switch cycles through the available selections.

Bank 0 Functions

FUNCTION	DESCRIPTION	DETAILS
0	BANK SEL	Toggle UP/LEFT to select BANK 1 Toggle DOWN/RIGHT to select BANK 0
1	INPUT MODE	0 = Auto Select 1 = 525 2 = 625
2	VBLANK	UP/LEFT = Narrow DOWN/RIG HT = Wide
3	SETUP	UP/LEFT = No Pedestal DOWN/RIGHT=AddPedestal
4	OUTPUT MODE	0 = Composite on all 1 = Y,Pb,Pr 2 = RGB 3 = Y/C
5	COMPONENT LEVELS	UP/LEFT = BETACAM 525 (Y, R-Y,B-Y) DOWN/RIG T = SMPTE EBU N-10/ BETACAM 625 (Y,Pb,Pr) (When OUTPUT MODE = Y,Pb,Pr)
6	INPUT SOURCE	Toggle DOWN to pass video. Toggle UP for Bars (Internal test signal)
7	<reserved>	
8	CLEAR USER SETUP	Toggle either way to clear User EEPROM and reset board
9	RESET	Toggle either way to reset board
A	<reserved>	
B	<reserved>	
C	<reserved>	
D	<reserved>	
E	STORE/RECALL	Toggle UP to store register Toggle DOWN to recall register
F	RESTORE DEFAULTS	Toggle either way to restore default settings

Bank 1 (Frame Sync Option Only)

FUNCTION	DESCRIPTION	DETAILS
0	BANK SEL	Toggle UP/LEFT to select BANK 1 Toggle DOWN/RIGHT to select BANK 0
	SET DEFAULT DELAY	Toggle UP/LEFT or DOWN/RIGHT = Restores FSC to factory defaults
2	SET LINE DELAY	Toggle UP/LEFT = increases OutputDelay by lines Toggle DOWN/RIGHT = Decreases Output Delay by lines
3	SET PIXEL DELAY	Toggle UP/LEFT = increases Output Delay by pixels Toggle DOWN/RIGHT = Decreases Output Delay by pixels
4	<reserved>	
5	<reserved>	
6	<reserved>	
7	<reserved>	
8	<reserved>	
9	<reserved>	
A	<reserved>	
B	<reserved>	
C	<reserved>	
D	<reserved>	
E	STORE/RECALL USER CONFIGURATION	Toggle UP/LEFT to Store Register Toggle DOWN/RIGHT to Recall Register
F	RESTORE DEFAULTS	Toggle UP/LEFT or DOWN/RIGHT to Restore Default Settings

Installation

Typically, R20CE installation consists of the following:

1. disconnect power from the frame (remove line cord)
2. remove the FR1/FR2 front panel
3. install R20CE card module
4. apply external color black reference at the frame's External Reference BNC
5. apply power to the frame by connecting a north american-style power cord from the frame to mains power (90 to 260 VAC)

Instructions for removing the frame front door for module installation is discussed in the *FR1/FR2 User Manual*.

External Reference Information

The R20CE expects the External Reference to be an NTSC or PAL analog Color Black signal. The External Reference input can come from two different sources on the R20CE. There are jumpers on the R20CE (see figure below) for selecting the external reference source and for optionally terminating the selected reference source.

Looping Reference

The R20CE cell group of 9 BNCs contains two BNCs that can be used for a looping reference connection. If this method is used, then the reference select setting on the R20CE should be set to "LOOP" and the TERMINATION setting should be set to "OFF" (no termination). Optionally, if you're using only one of the looping reference BNCs, then the TERMINATION setting should be set to "ON."

Frame Reference

Alternatively, the R20CE installed in a FR1 or FR2 frame can use the frame's *frame reference input* BNC connector, which feeds an external reference video signal to all modules installed in the frame. How the signal is distributed differs for the FR1 and FR2 frames. Additionally, individual modules can usually be strapped as to whether external reference is distributed from the frame or directly to BNCs on the module's corresponding cell group (the 9 BNCs on the rear panel).

FR1 Frame: the external reference signal is distributed passively to all frame modules. If you wish to use the frame reference, the R20CE should have "FRAME" reference selected on the module strapping, and one and only one card in the frame should have "TERMINATION" set to "ON." All other cards in the frame should have TERMINATION set to "OFF."

FR2 Frame: the external reference signal is distributed by an in-frame distribution amplifier to all frame modules. This system terminates the Frame Reference input BNC and buffers the signal to all slots. If using frame reference, the R20CE installed in the FR2 frame should have "FRAME" set for reference select, and all cards should have TERMINATION set to "OFF."

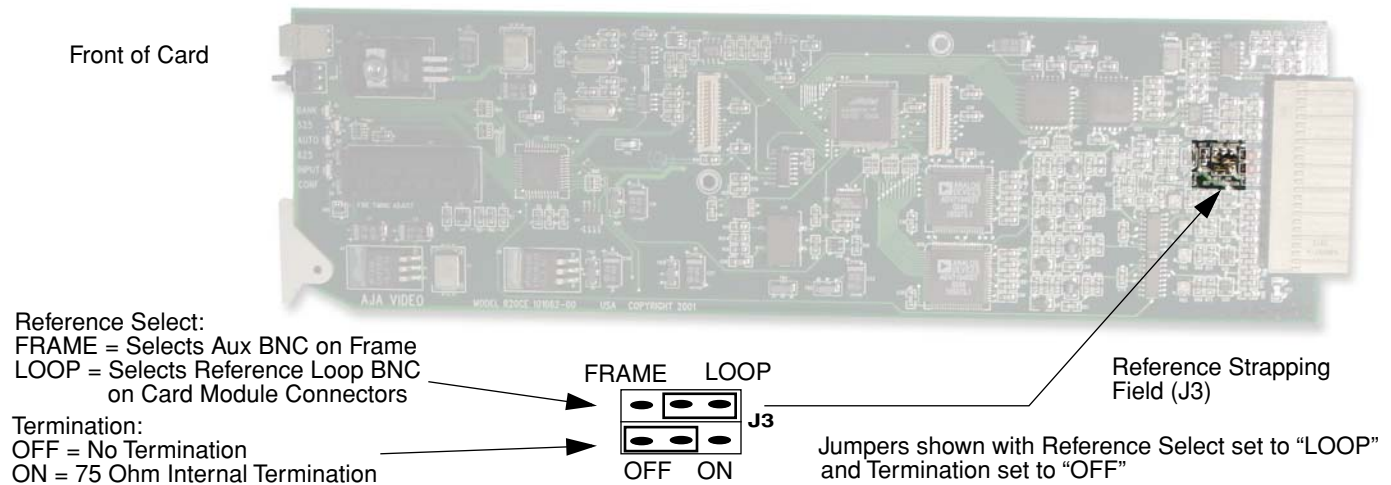

Reference Select and Termination Configuration

Output Timing Adjustment (With Model FSG Framesync/Genlock Option)

The following procedure provides instructions for output timing adjustment of the R20CE when used with the model FSG FRAMESYNC/GENLOCK option.

The R20CE has three levels of output timing adjustment:

- advance or delay by lines
- advance or delay by pixels (with 1/4 pixel resolution)
- fine timing adjust (+/- 40 nanoseconds)

There are two modes of timing adjustment:

- Genlock
- Delay

If the R20CE detects an external reference, it then enters Genlock mode. If no external reference is detected, the board enters Delay mode. In Genlock mode, the R20CE output genlocks to the external reference. The board can be set to Delay mode without removing the external reference by lifting the "REFERENCE SELECT" jumper (J3).

Genlock Mode

1. Perform function 1 in Bank 1 "*SET DEFAULT DELAY*." This brings the output timing close to the reference's timing.
2. Perform function 3 in Bank 1 "*SET PIXEL DELAY*." This will allow adjustment to within 1/4 pixel of reference.
3. Adjust the "*FINE TIMING ADJUST*" control on the front of the R20CE board for precise exact timing (refer to photo provided).

Delay Mode

1. Perform function 1 in Bank 1 "*SET DEFAULT DELAY.*" This action sets the total delay through the R20CE to about 1 frame.,
2. Perform function 2 in Bank 1 "*SET LINE DELAY.*" This allows you to advance and delay the output timing in line increments.
3. Perform function 3 in Bank 1 "*SET PIXEL DELAY.*" This allows you to advance and delay the output timing in Pixel increments.

Note: In "*SET PIXEL DELAY,*" the first four increments are 1/4 pixel steps.

4. Adjust timing as desired anywhere between the steps set above by adjusting the "*FINE TIMING ADJUST*" control on the front of the R20CE board.

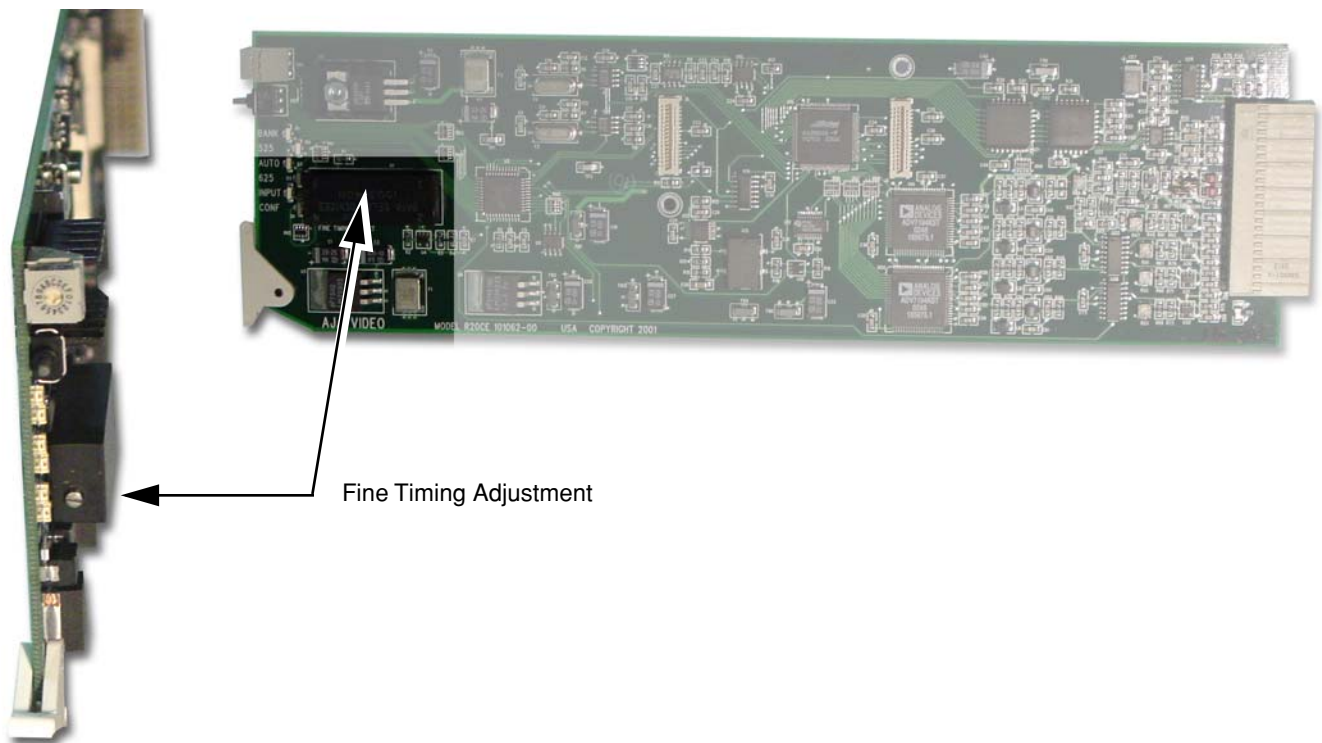

R20CE Fine Timing Adjustment Control Location

Specifications

Item	Specification
Input Format:	SMPTE 259 / ITU-R-601 Serial Digital Component
Primary Output Format:	NTSC, PAL, Y/C (S Video)
Active Looping Output:	SMPTE 259 / ITU-R-601 Serial Digital Component
Reference Input Format:	NTSC or PAL Analog Color Black
SDI Cable Equalization:	300 meter 8281 typical
Serial Output:	Equalized, Re-clocked
Return Loss:	Serial Input:15 dB to 300MHz, Serial Output:15 dB to 300MHz
FrequencyResponse:	+/- 0.25dB to 5.5MHz (Y) +/- 0.25dB to 2.0Mhz (Chroma - Component, RGB) +/- 0.25dB to 1.3Mhz (Chroma - Composite)
2T K factor:	<1% (Y)
Diff. Gain:	<1.5%
Diff. Phase:	<1.5 degree
Y/C delay:	10 ns max
D/A Converters:	10 bits
Signal Path:	10 bits
Delay (input to output):	6.2 microseconds (without Framesync option installed)
Output level matching:	1.5% or 10mv (All outputs are separately buffered)
Output level adjustment:	+/-20% (internal)
Power Consumption:	6.0 W (w/o FSG Framesync) 7.5 W (w/ FSG Framesync)

